

Framtida bränsleval för flyg, sjöfart och vägtransporter ur ett systemperspektiv

Julia Hansson (IVL), Selma Brynolf, Karna Dahal, Elin Malmgren
Maria Grahn (all Chalmers), Erik Fridell & Martin Hagberg (IVL)



Main message:

- Introduction of alternative aviation and shipping fuels will play crucial role in decarbonizing Nordic transport sector.
- Bio-jet fuels and shipping biofuels represent cost-effective mitigation measures in Scandinavia.
- CCS and BECCS (carbon capture and storage from biomass) important as well as policies.

Decarbonizing Nordic Transports – the Role of Different Alternative Transport Fuels

Julia Hansson, Martin Hagberg, Selma Brynolf, Maria Grahn, Kenneth Karlsson (IVL, Chalmers), model development also by DTU



Aim

- To assess what alternative fuel options that are cost-effective for aviation, shipping and road transport (heavy and light) in the future Scandinavian region (Sweden, Norway and Denmark) in an energy system context given carbon reduction requirements
- Identify key factors that influences the prerequisites for different options

Background

- The potential role of different alternative transport fuels in different sectors will beside technical and cost development depend on the development in other sectors
- Transforming transport is a key energy challenge in the Nordic region to achieve the ambitious climate targets



Method: Newly developed TIMES Nordic model

- Bottom-up, optimization (cost minimization) energy system model
- Comprehensive coverage of the national energy system: Power and heat sector, transport sector, industry and service sector, residential sector
- Coverage: Sweden, Norway and Denmark
- Time period: 2010-2050
- The model satisfies the defined modal demands for the entire time horizon by deploying the technology mix with the lowest levelised costs while fulfilling the CO2 constraint (no net CO2 emissions by 2050)

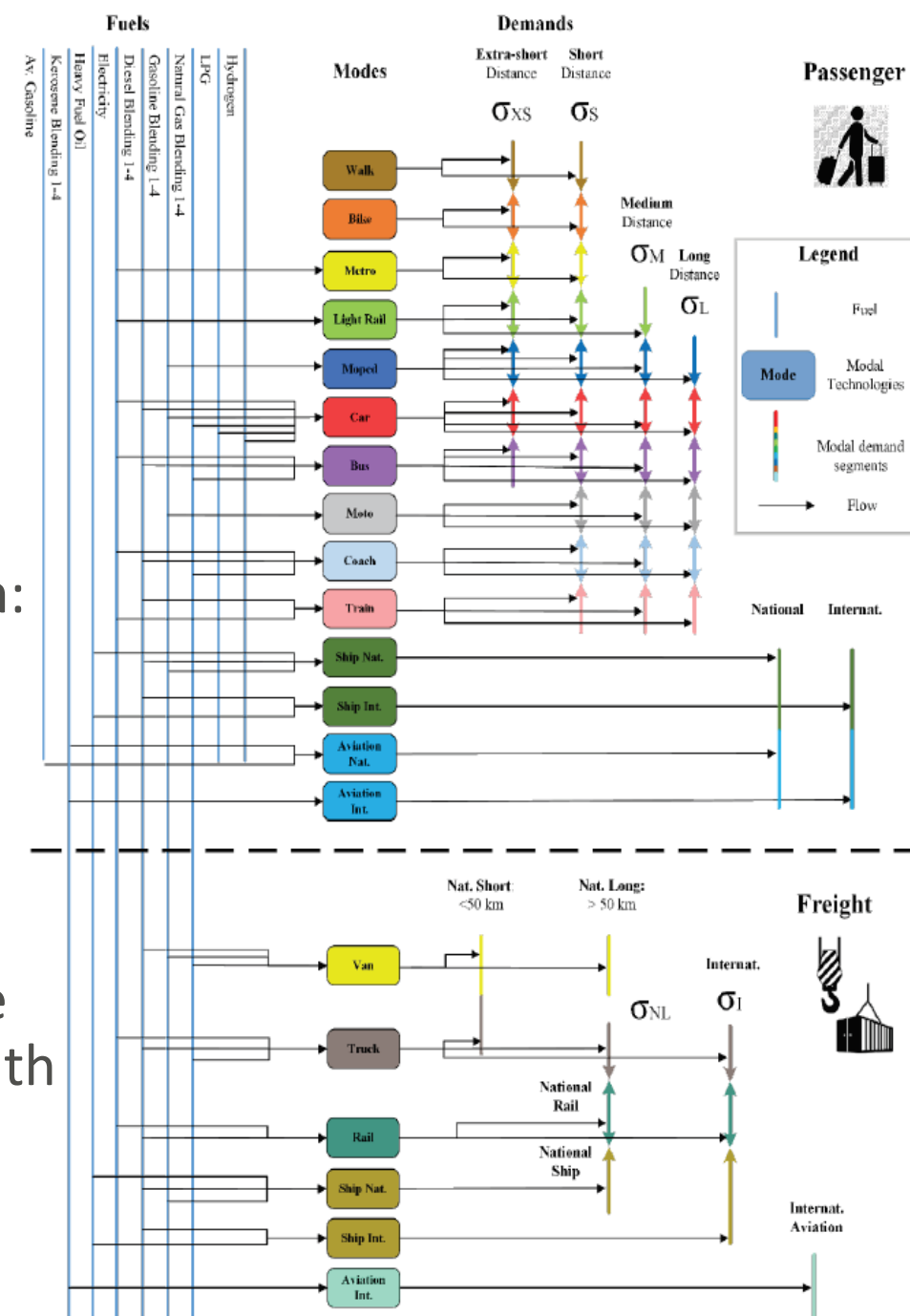

Important assumptions

- Road transport fuel options: conventional fossil fuels, biofuels (liquid and gas), electricity, hydrogen and electrofuels
- Aviation fuel options: conventional jetfuels, bio-jetfuels, hydrogen and electrofuels
- Shipping fuel options: conventional fuels, biofuels, hydrogen and electrofuels
- Consider cost estimates, technical performance, CO₂ emissions
- Domestic and international shipping and aviation is included (represented by the share filled in the included countries)
- Several scenario cases:
 - biofuel import bound,
 - carbon capture and storage (CCS),
 - high cost for electric and fuel cell vehicles,
 - intro of shared autonomous cars,
 - shift & avoid measure (transport demand)

Scenarios for fuel use in entire Scandinavian transport sector - no net CO2 emissions by 2050

Biofuels and electricity in all cases. Electrofuels only in case of no CCS

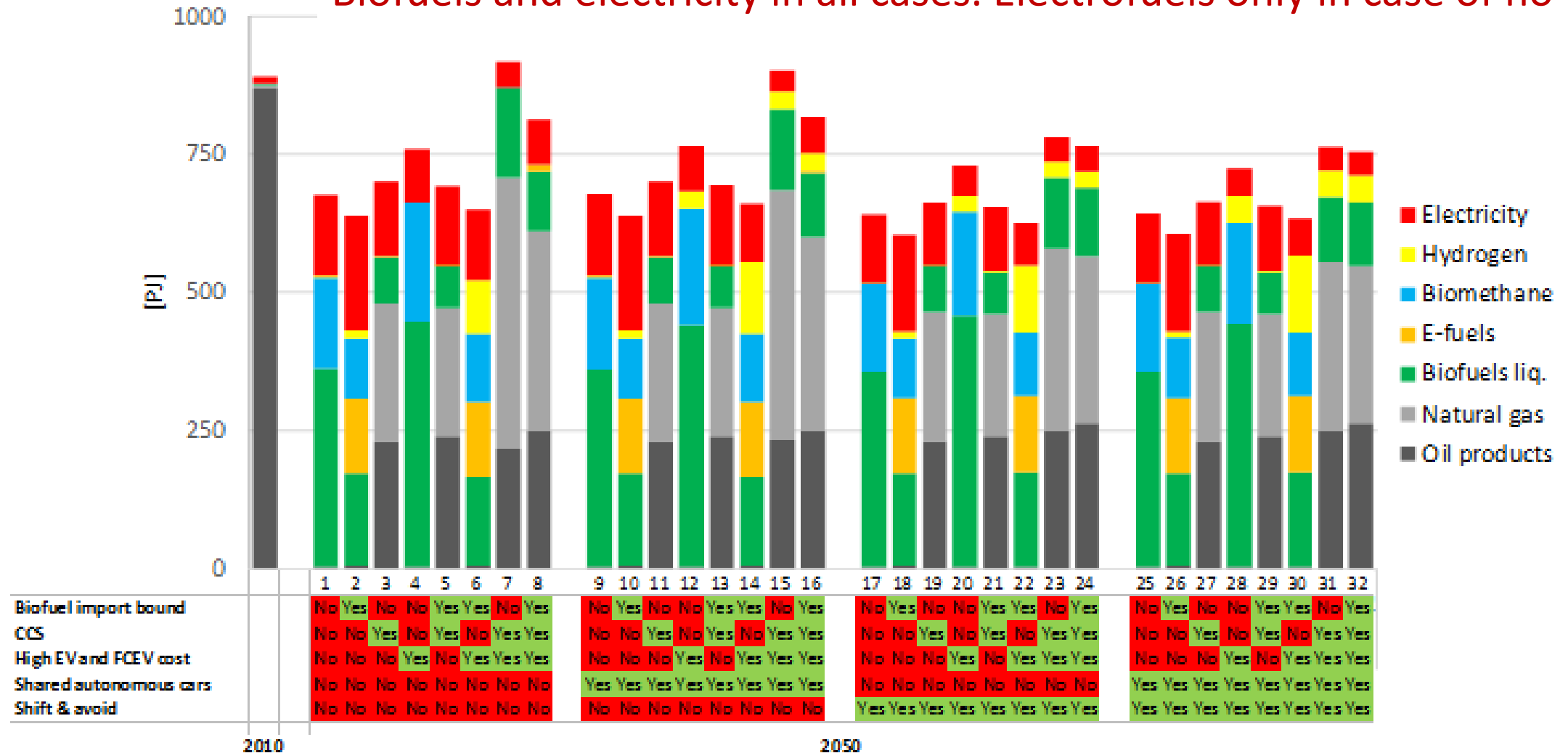

Fuel use in Scandinavian road sector (light duty) in 2030 and 2050 for 8 different scenario cases

No net CO2 emissions by 2050

Strong electrification, Role of biofuels, No electrofuels

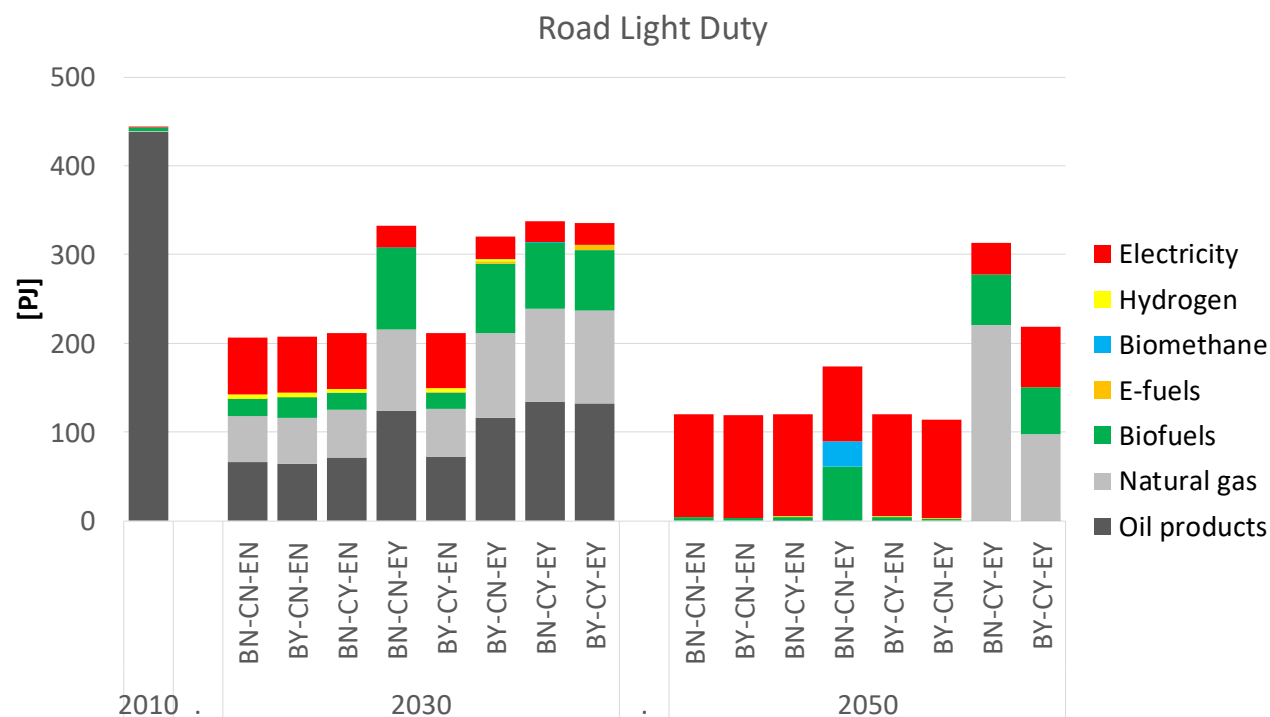

E-fuels: electrofuels (produced from CO2 and H2O using electricity)

BN/Y: biofuel import bound Yes/No,

CN/Y: Carbon capture and storage (CCS) Yes/No,

EN/Y: High electric and fuel cell vehicle cost Yes/NO

Fuel use in Scandinavian aviation sector in 2030 and 2050 for 8 different scenario cases

No net CO2 emissions by 2050

Aviation

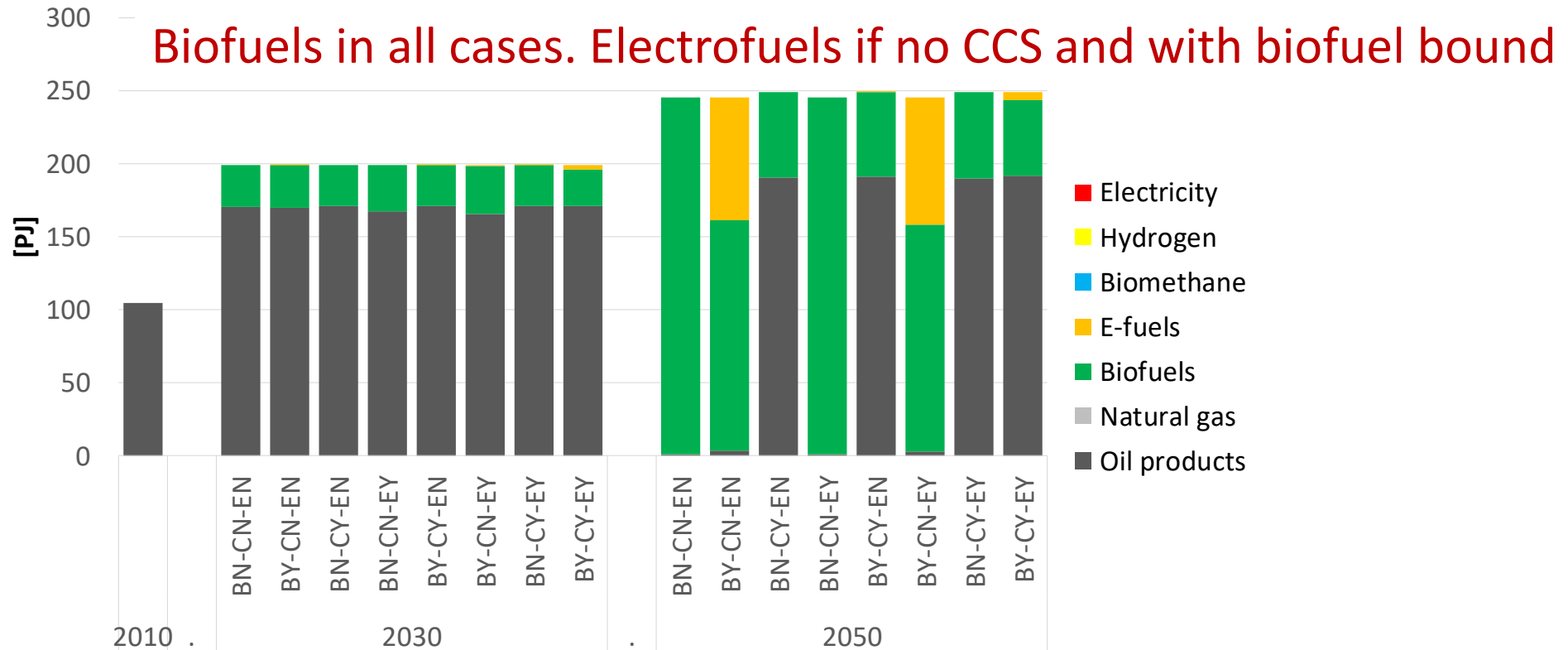

E-fuels: electrofuels (produced from CO2 and H2O using electricity)

BN/Y: biofuel import bound Yes/No,

CN/Y: Carbon capture and storage (CCS) Yes/No,

EN/Y: High electric and fuel cell vehicle cost Yes/NO

Fuel use in Scandinavian shipping sector in 2030 and 2050 for 8 different scenario cases

No net CO2 emissions by 2050

Biofuels in all cases. Electrofuels if no CCS and with biofuel bound

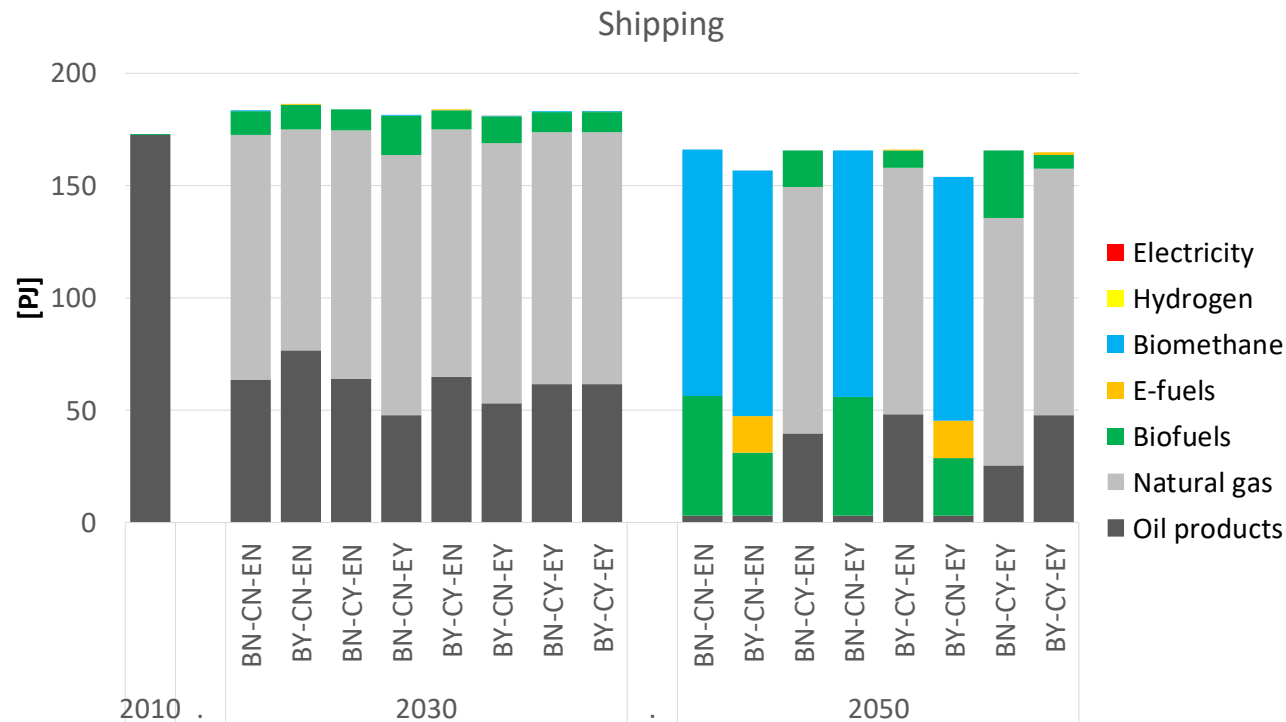

E-fuels: electrofuels (produced from CO2 and H2O using electricity)

BN/Y: biofuel import bound Yes/No,

CN/Y: Carbon capture and storage (CCS) Yes/No,

EN/Y: High electric and fuel cell vehicle cost Yes/NO

Fuel use in Scandinavian road sector (heavy duty) in 2030 and 2050 for 8 different scenario cases

No net CO2 emissions by 2050

Biofuels initially, More unclear in long-term

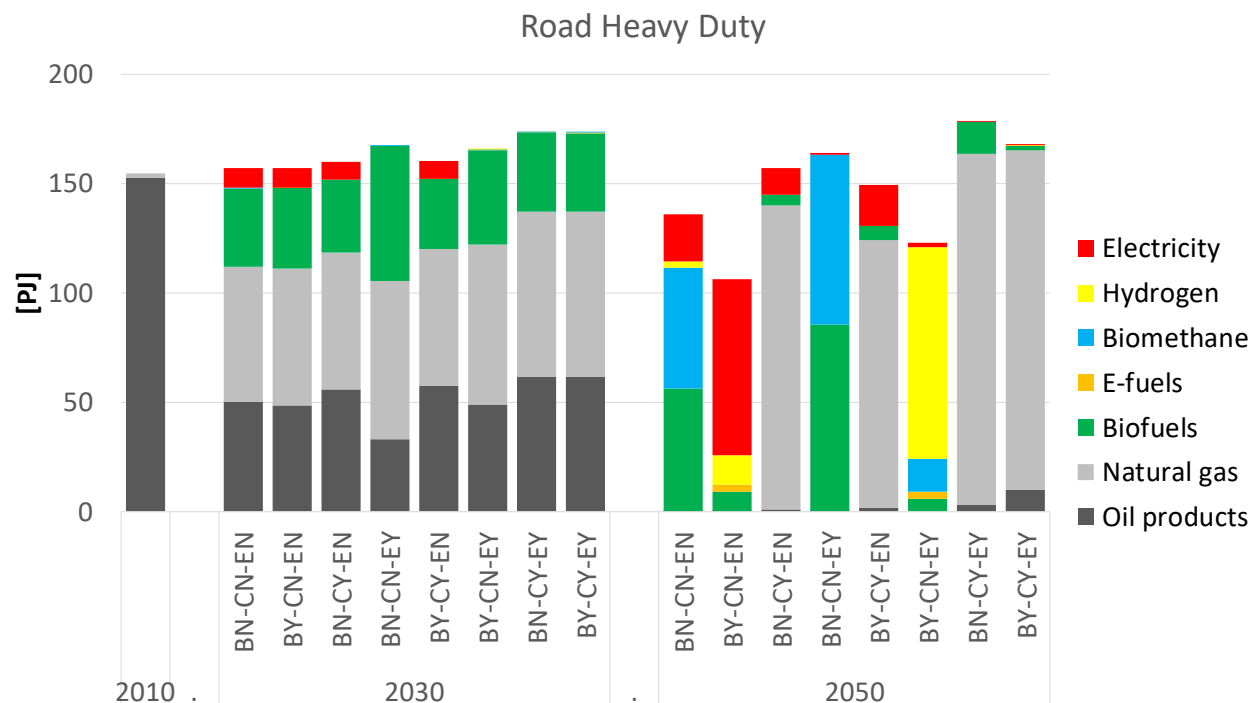

E-fuels: electrofuels (produced from CO2 and H2O using electricity)

BN/Y: biofuel import bound Yes/No,

CN/Y: Carbon capture and storage (CCS) Yes/No,

EN/Y: High electric and fuel cell vehicle cost Yes/NO

Main findings (1/2)

- Fuel switch and more efficient use of transport: A combination of transport mitigation measures is cost-effective for decarbonizing transport.
- A considerable electrification and shift towards low energy intense modes seem cost-effective for passenger and freight road transport.
- Biofuels are needed too, not least in shipping and aviation.
- A cost-effective fuel and technology mix in the Nordic transport sector depend on several key factors including:
 - development of CCS and bio-CCS
 - expansion of low-carbon electricity generation
 - availability of sustainable biofuels
 - cost development of electrified options
 - development of hydrogen based solutions

Main findings (2/2)

- Introduction of alternative aviation and shipping fuels will play crucial role in decarbonizing Nordic transport sector.
- Bio-jet fuels and shipping biofuels is indicated to represent cost-effective mitigation measures in Scandinavia for 2030 and 2050 in all studied scenarios. **BECCS important**
- Electrofuels to some extent also a cost-effective option for aviation but only when CCS is not deployed in large-scale.
- Hydrogen does not seem cost-effective for aviation and shipping in assessed cases, but further assessment needed before any firm conclusions can be drawn on the potential role for hydrogen in the Nordics. Globally different case?
- Updated cost estimates for different fuel production pathways and propulsion systems will improve the assessment (also electric shipping solutions)

Policies and their design one key!

Scenarios for Scandinavian CO2 transport emissions with no net CO2 emissions by 2050

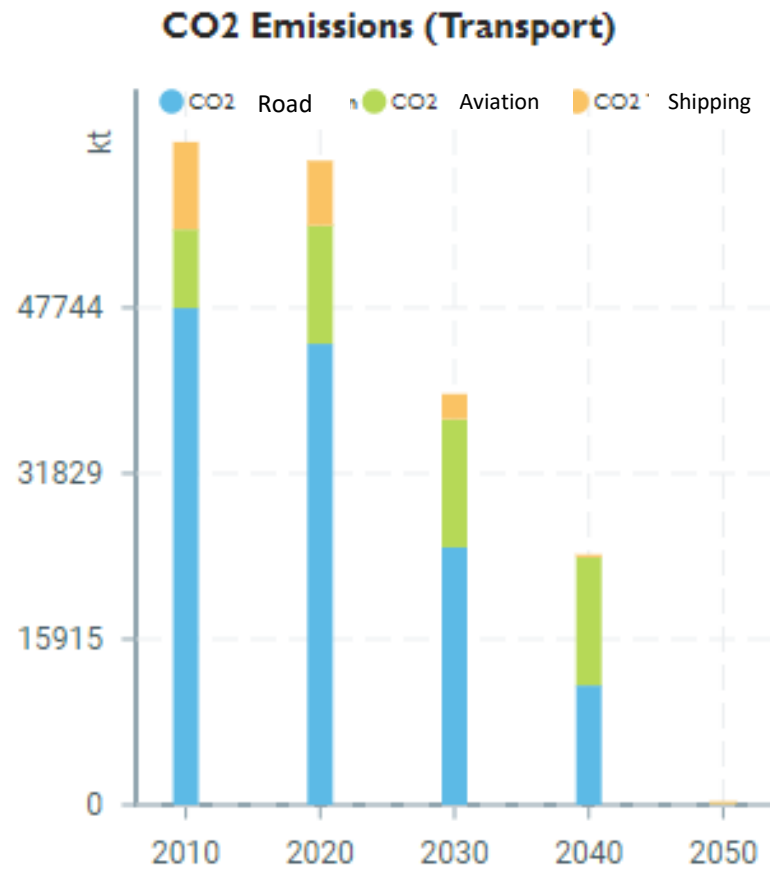

Transport CO2 emissions - **No CCS**

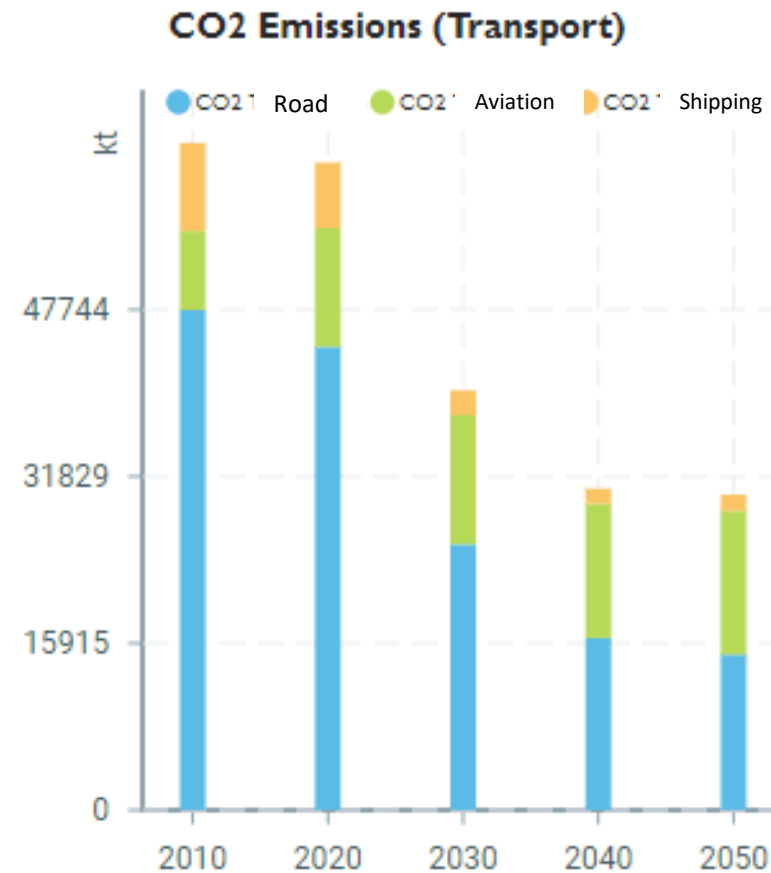

Transport CO2 emissions - **With CCS**

Tack för er uppmärksamhet!

Frågor?

julia.hansson@ivl.se

Det här projektet genomförs inom samverkansprogrammet *Förnybara drivmedel och system* som finansieras av Energimyndigheten och f3 Svenskt kunskapscentrum för förnybara drivmedel.

www.f3centre.se/samverkansprogram



SVENSKT KUNSKAPSCENTRUM
FÖR FÖRNYBARA DRIVMEDEL

